



SIP Advantage[®]

Smart VoIP for Smart Business

innovation
automation
experience
leadership

delivering on the promise of VoIP

SIP ADVANTAGE®: THE SMART CHOICE

SIP Advantage® enables your business to capture the full benefits afforded by VoIP and puts the power of VoIP in your hands providing you with;

- The only truly scalable VoIP solution for all types of business locations,
- Increased functionality for a more productive workforce,
- Better control and visibility into business operations and activity,
- Improved business continuity to ensure customer access,
- Substantial savings in both monthly expenses and administrative costs,
- Simplified user experience with comprehensive automation,
- Unmatched technical expertise with VoIP solutions

SIP Advantage® is the first VoIP solution truly designed to meet the wide range of today's, and tomorrows, business needs.

SMART SOLUTIONS THAT FIT YOUR NEEDS

VoIP solutions can provide great value but only if they fit your business environment effectively. Not all customers are the same, and not all locations are the same for a single customer – so why should you be asked to use the same solution everywhere?

SIP Advantage® provides a single source VoIP solution that not only provides you with great functionality and value, but also superior flexibility. Regardless of your requirements, SIP Advantage® has a solution. Choosing the right solution is as easy as asking the following questions:

1. How would you like to improve your current communications solution?
2. Are you willing to entertain moving to an entirely new phone system? **Host the system with OfficeFone!**
3. Do you currently have a PBX that you want to continue using? **VoIP enable it with OfficeTrunk!**
4. Do you currently have a Key system that you want to keep using? **VoIP enable it with OfficeLine!**



AUTOMATED DELIVERY PROCESSES

Avoid the delays, and eliminate the complexity with SIP Advantage®. Leveraging its unique proprietary service platform, Rialto®, Adaption Technologies removes the complexity and challenges relating to delivering VoIP services – getting service turned up faster, cleaner, and easier than the competition.



WEB BASED ACCESS

Access administrative or end user dashboards from any computer, any time. Adjust configuration, redirect calls, check voicemail, view order status, review invoices – anytime, anywhere.

SIP Advantage® provides unique, secure login access to each user to manage their services based on the role you define for them.



SIMPLICITY

The easier a tool is to use, the more effective it will be. SIP Advantage® was designed with this philosophy in mind. With simple point and click interfaces, and minimal requirements from your users, SIP Advantage® truly delivers the power of VoIP in an intuitive manner for easy implementation and adoption.

hosted VoIP for smart business

OFFICEFONE

Hosted VoIP solution that delivers the business value of VoIP to small and medium business locations in an easy to use, easy to manage, affordable package. SIP Advantage OfficeFone® delivers all the business-class telephony features you've come to expect, plus enhanced capabilities only available with VoIP – making capabilities once reserved for large enterprises available to businesses of all sizes, at a fraction of the cost.

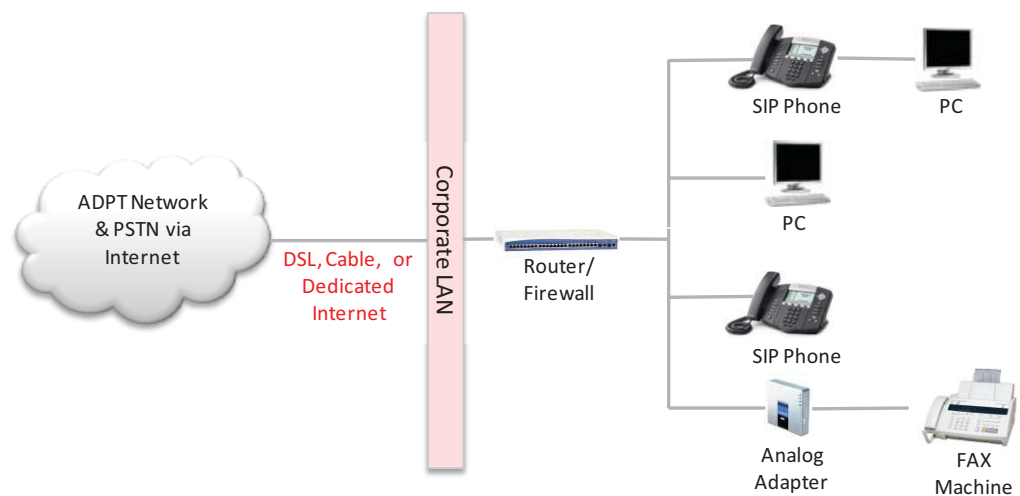

KEY BENEFITS

- SINGLE CONVERGED NETWORK, NO NEED FOR AN ONSITE PHONE SYSTEM, OR THE PRI/POTS LINES TO SUPPORT THEM.
 - REDUCES MONTHLY LINE EXPENSE
 - REDUCES INITIAL INVESTMENT
 - REDUCES MAINTENANCE EXPENSE
 - REDUCES ADMINISTRATIVE EXPENSE
- EASY TO USE DASHBOARDS MAKE THE MANAGEMENT AND USE OF CAPABILITIES INTUITIVE AND EASY TO IMPLEMENT
- ROBUST FEATURE FUNCTIONALITY THAT IS AUTOMATICALLY UPGRADED WITH NEW TECHNOLOGY AS IT IS INTRODUCED – NO MORE OBSOLETE SYSTEMS
- FREE CALLING BETWEEN SIP ADVANTAGE® CUSTOMERS
- SCALABLE SOLUTION TO FIT INDIVIDUAL USER NEEDS AND GROW ALONG WITH YOUR BUSINESS ENVIRONMENT
- CENTRALIZED ADMINISTRATION FUNCTIONALITY FOR SIMPLIFIED MULTI-LOCATION ADMINISTRATION
- DISASTER RECOVERY SOLUTION TO AUTOMATICALLY REDIRECT INCOMING CALLS TO DESTINATION OF CUSTOMER'S CHOICE AS NEEDED
- REMOTE USER SOLUTIONS WITH APPROPRIATE 911 REGISTRATION
- REAL TIME CALLING SCOPE CHANGES VIA DASHBOARD FOR DYNAMIC LOCAL PRESENCE PRESENTATION

CUSTOMER EXPERIENCE

Regional Retailer

Moved to hosted solution for over 20 retail locations throughout the Midwest to replace outdated key system solution for improved communications, cost savings, and simplified administration

THE RESULT

- Over 50% savings in upfront costs versus premise based options
- Monthly savings of ~40%
- Centralized administrative control eliminating travel and 3rd party expenses
- Improved quality and resiliency of service

VoIP enabling smart business

OFFICETRUNK & OFFICELINE

SIP Advantage OfficeLine® and OfficeTrunk® are easy entry points into the world of VoIP for businesses with functional Key System's or PBX's. Take advantage of the efficiencies of a single network by eliminating your POTs lines or PRI's, enhanced service control, and improved business continuity – while using your existing system.

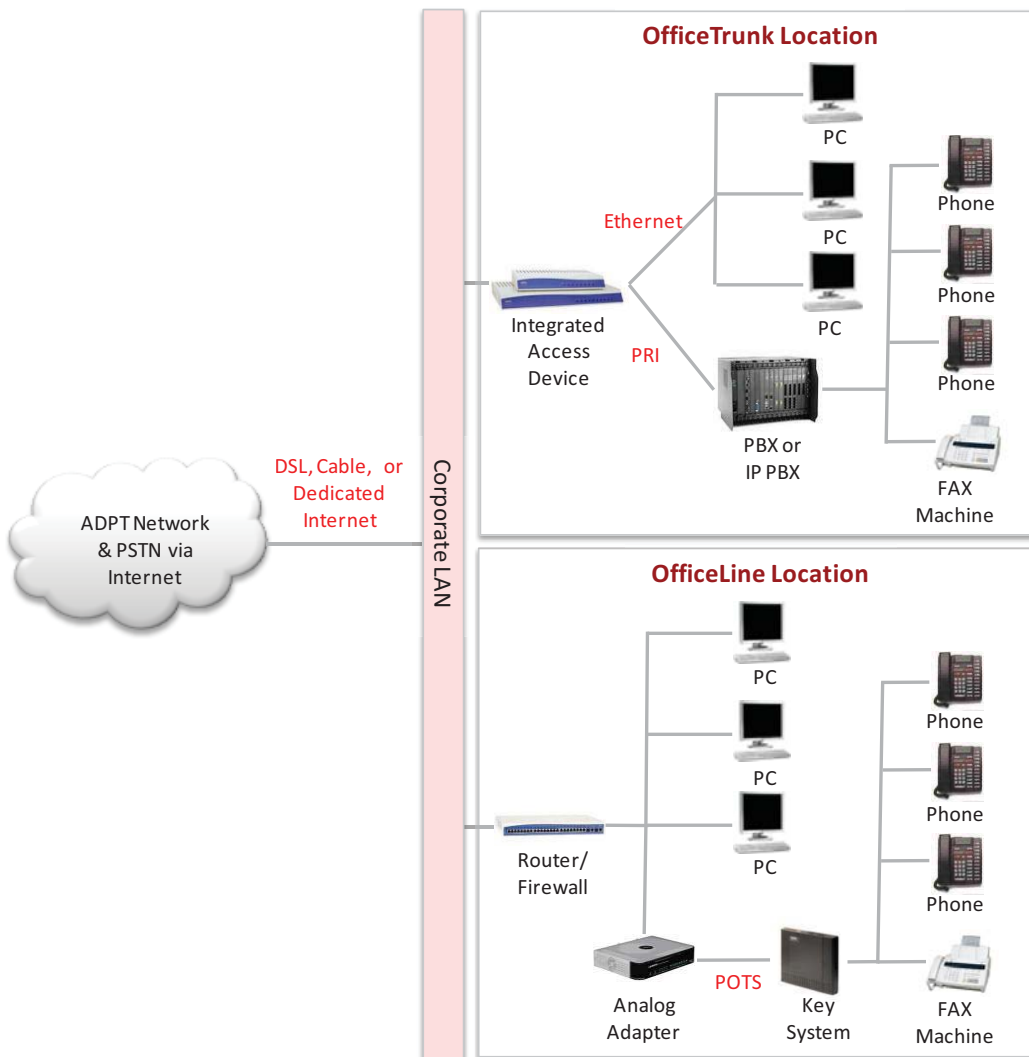

KEY BENEFITS

- SINGLE CONVERGED NETWORK FOR VOICE AND INTERNET NEEDS, NO NEED FOR THE PRI/POTS LINES TO SUPPORT YOUR PHONE SYSTEM
 - REDUCES MONTHLY LINE EXPENSE
 - MINIMAL INITIAL INVESTMENT
 - REDUCES ADMINISTRATIVE EXPENSE
- CENTRALIZED, EASY TO USE DASHBOARDS MAKE THE MANAGEMENT OF HUNT GROUPS, CAPACITY ASSIGNMENTS, LOCAL CALLING PRESENCE, AND OTHER CAPABILITIES INTUITIVE AND EASY TO IMPLEMENT.
- LEVERAGES EXISTING INVESTMENT IN PBX OR KEY SYSTEM AND PHONES
- ADDS FUNCTIONALITY WHILE MAINTAINING CURRENT USER ENVIRONMENT FOR EASY IMPLEMENTATION
- DISASTER RECOVERY SOLUTION TO REDIRECT INCOMING CALLS TO DESTINATION OF CUSTOMER'S CHOICE AS NEEDED
- FREE CALLING BETWEEN SIP ADVANTAGE® CUSTOMERS

CUSTOMER EXPERIENCE

National Non-Profit Organization

VoIP enabled over 200 locations across the country to improve employee and customer communications, while cutting costs.

THE RESULT

- Reduced monthly expenses by ~40%
- Added ability to change local calling appearance real time to support campaigns
- Increased visibility into call volumes and activity
- Centralized administrative control
- Leveraged existing phone systems, phones, and internet connections

EVOLVING THE IP SERVICES ENVIRONMENT

Adaption Technologies' corporate mission is to revolutionize how businesses achieve success through the simplified, scalable, and cost effective integration of IP technology. While this mission is ambitious, it is possible. And important.

Our leadership team understands this firsthand. With more than 150 years of combined experience in changing the ways businesses employ technology, and enabling partners to expand their offerings and grow their businesses, the Adaption Technologies leadership team brings a highly refined perspective to the current state of IP services and the untapped potential that remains.

Adaption Technologies is a leading innovator of tools that simplify the delivery of IP based services. We have drawn upon our own extensive experience as IP services operators to develop a next-generation VoIP solution that features increased functionality, flexibility, scalability, and value, along with a powerful suite of service administration and e-commerce tools for self service by end users. Our solutions adapt to your unique business environment to deliver the power of VoIP into your hands.



ON TARGET IT SOLUTIONS

42 Star Spangled Ln.
Peachtree City, GA 30269
770.755.1457 ph
www.OnTargetITS.com
sales@OnTargetITS.com



1009 Pruitt Rd.
The Woodlands, TX 77380
281.465.3320 ph
281.465.3354 fax
www.sipadvantage.com
www.adpt-tech.com